

Bu Çizim MESA OTO ELEKTRİK LTD.ŞTİ'nin malıdır. Şirket Yetkilerinin izni olmaksızın kopya edilemez, üzerinde değişiklik yapılamaz. This Drawing MESA AUTO ELECTRIC LTD 's are property. Can not be copied without the consent of the company authorized, any changes can be made.

PARÇA KODU PART CODE	PARÇA ADI PART NAME	Malzeme Material	Kaplama Coating
TŞB 2562 RP	TOPRAKLAMA KLEMENSİ Ø3.7 =RP=	(CuZn30) Pirinç / Brass	—
TŞB 2562 RPK	TOPRAKLAMA KLEMENSİ Ø3.7 =RPK=	(CuZn30) Pirinç / Brass	Kalay / Sn (3-5µ)
TŞB 2562 RS	TOPRAKLAMA KLEMENSİ Ø3.7 =RS=	Kalay kaplı Sac / Tin Coated Sheet	Kalay / Sn

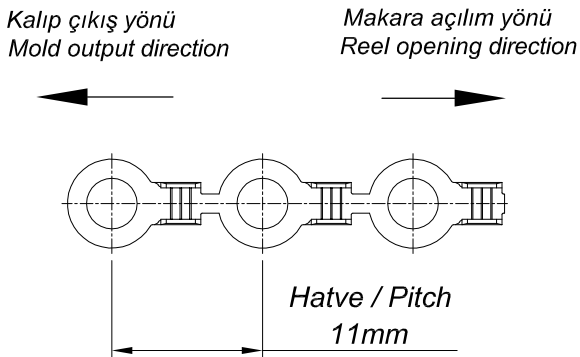
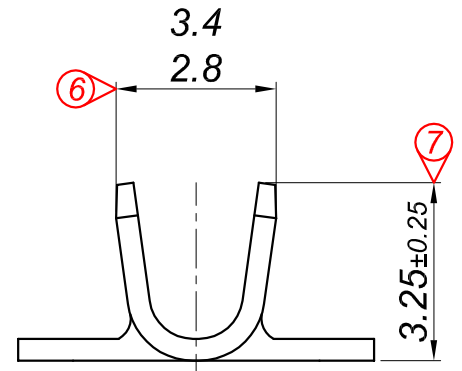
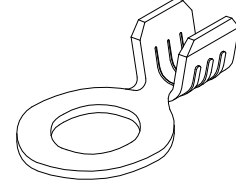
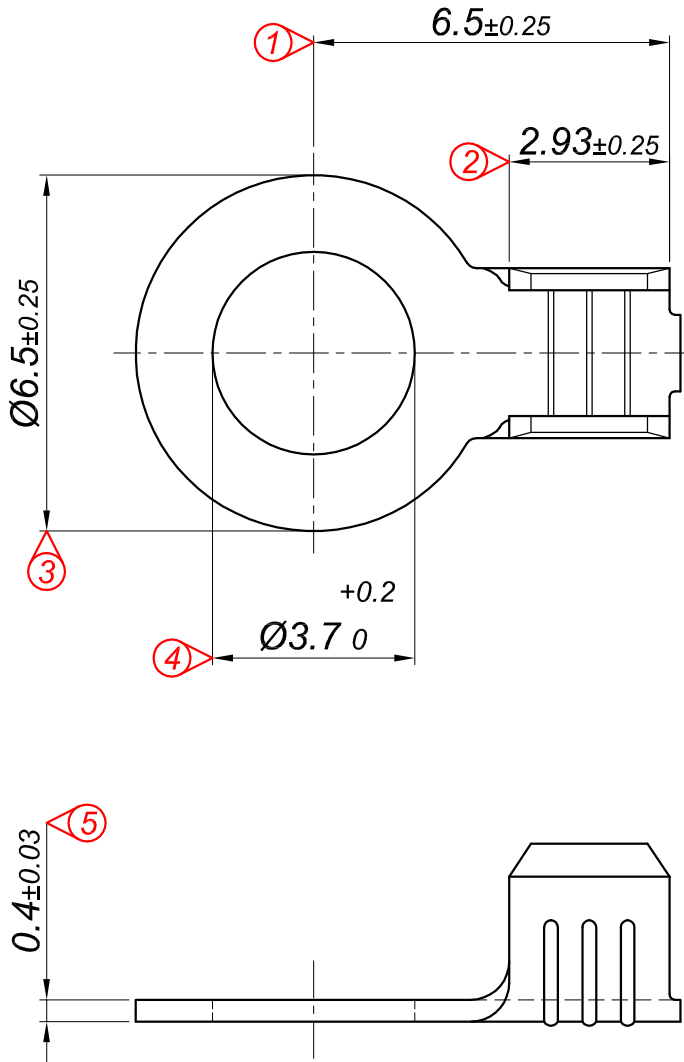

Kablo Kesiti
Wire Section : 0.50 - 1.50 mm²

Resim üzerinden ölçü almayınız
do not measure on drawing

Tarih / Date	23.01.2019	İmza /Signature	Ölçek /Scale		
Çizen / Desing	M.Yağcı				
Onay / Approval	Ç.Yeşil		8 / 1	No	Değişiklik / Revision
					Tarih/Date



Parça Adı:
Part Name

TOPRAKLAMA KLEMENSİ Ø3.7

Parça Kodu:
Part Code

TŞB 2562